



Book of Museum Policies and Best Practices

Safety Rules



May 6, 2018

1.0

Table of Contents

Glossary	2
Safety Policy	4
S1.0 Safety Rules	4
S2.0 Injury, Illness, Accidents	5
S2.1 Visitor Injury or Illness.....	5
S2.2 Personal Injuries and Accidents.....	5
S2.2.1 Care for Injured.....	5
S2.2.2 Equipment Inspection	5
S2.2.3 Mechanical Inspection	6
S2.2.4 Reporting.....	6
S3.0 Key Safety Rules	6
S4.0 General Safety Rules	6
S5.0 Job Safety Briefing	10
S6.0 Personal Protective Equipment and Clothing (PPE)	10
S7.0 General Work Environment	12
S7.1 Working around Shops and Maintenance	12
S7.2 Working around Museum and Moving Equipment	24
S7.3 On or Near Tracks, Locomotives and Rail Cars	28
S7.4 Steam Locomotive Safety	32
S8.0 Blue Signal Protection of Workman	34
S9.0 Chemical Safety	39
S10.0 Electrical Safety	39
S11.0 Cutting and Welding Equipment Safety	40
S11.1 General.....	40
S11.2 Electric Welding	41
S11.3 Cutting (Gas Burning).....	41
S12.0 Fire Prevention, Response and Hazards	42

Glossary

Cars

Railroad cars that include all locomotives, freight, passenger cars, motors (Geese) and other rolling equipment.

Cardinal Safety Rules

Major safety rules for all personnel as indicated with an * *in bold font*.

Clearance Point

The location closest to a switch where it is safe for equipment, and a person riding the side of equipment unless prohibited, to pass equipment on an adjacent track.

Conductor

Personnel in charge of train or yard movement.

Crew Member

Conductors, brakemen, engineers, fireman, motorman, hostlers and switchmen

Engine

A unit propelled by any form of energy or more than one of these units operated from a single control. Engines are used in train or yard service. Rules that apply to engines also apply to motors (geese). Motor track cars (speeders, pop cars) are not “engines”)

Engine and Car Repair and/or Service Area (Roundhouse)

One or more tracks within an area where engine and/or rolling equipment testing, servicing, repairing, inspecting, or rebuilding is performed. (Roundhouse tracks and Roundhouse lead.)

Engineer

Operates the locomotive and includes student engineers, firemen, motorman.

Equipment

Railroad cars, locomotives, motors (Geese), etc.

Foreman

Personnel in charge of work.

Main Loop Track

The main circle of track extending around museum on which trains are operated.

Mechanical Foreman

Person in charge of mechanical personnel.

Men or Equipment

A term referring to Maintenance of Way (MOW) personnel and their related equipment.

Motor

All historic “Galloping Geese” equipment.

Personnel

All museum employees and volunteers.

Track Foreman

Rules qualified person in charge of personnel working on track.

Safety Rules

Safety Policy

The Executive Director and Board of Trustees of the Colorado Railroad Museum are committed to the health and safety of our personnel, volunteers, and guests.

To fulfill this commitment, all of us must make health and safety an integral part of our work experience. We must take personal responsibility for our actions and adhere to safety policies, rules, and regulations at all times.

The Colorado Railroad Museum is committed to provide the leadership, organization, training, and resources needed to maintain a healthy and safe working environment. All personnel and volunteers must make a personal commitment to safety and perform their work in a manner that will prevent accidents to themselves, their fellow workers and our guests.

The Colorado Railroad Museum has a positive safety culture that we strive to continually improve. Safety culture begins with top level management's shared values, actions and behaviors that demonstrate commitment to safety and is applied throughout the organization. We encourage open communication between personnel, volunteers and management. We empower our personnel to identify and report safety issues. We foster an environment of trust, encouraging error-reporting and discourage covering up mistakes.

We appreciate your full cooperation to follow the Colorado Railroad Museum's safety program and make our workplace safe, healthy and injury-free.

S1.0 Safety Rules

These rules provide a core of safe work practices for Colorado Railroad Museum personnel and volunteers. The rules apply every day and in every job, we do. They will guide and direct us in maintaining a safe work environment. The Colorado Railroad Museum is committed to your safety and this information is a vital component to help you make solid and safe decisions while you perform work at the museum. These rules are grouped under headings for convenience. A rule from any heading must be observed if it covers the duties being performed. The term "*Personnel*" includes both employees and volunteers at the Colorado Railroad Museum. *Any rule with an * is considered a Cardinal Safety Rule.*

S2.0 Injury, Illness, Accidents

S2.1 Visitor Injury or Illness

- Immediately report any incident to front office and notify 9-1-1 if medical assistance is required. Provide the following information:

- ✓ **Contact Person:** Your name and phone number
- ✓ **Location:** Colorado Railroad Museum
17155 West 44th Avenue
Golden, CO 80403
- ✓ **Nature of Injury:** What is the Injury?

- Do not attempt any type of first aid other than for minor cuts or scratches.
- Stay with injured person until emergency personnel arrive. If necessary, send someone to front gate of parking lot to direct emergency personnel to location of injured person.
- Make every effort to obtain in writing name, address and phone number of injured person, name and phone number of relative to be notified, and names, addresses and phone numbers of any witnesses to incident.
- If executive director or business manager are not on premises, both should be notified as soon as possible.
- It is important to offer every possible courtesy and attention to the injured person.
- A written report of the incident must be completed as soon as possible.

S2.2 Personal Injuries and Accidents

S2.2.1 Care for Injured

When passengers or personnel are injured, do everything reasonable to care for them. Do not attempt any type of first aid other than for minor cuts or scratches unless qualified in First Aid, CPR or other certified medical training as applicable.

S2.2.2 Equipment Inspection

If an accident results in personal injury or death, all tools, machinery, and other equipment involved, including the accident site, must be inspected promptly by the foreman, another person in charge of the work, or other competent inspectors.

S2.2.3 Mechanical Inspection

When engines, cars, or other equipment are involved in an accident that results in personal injury or death, the equipment must be inspected before it leaves the accident site.

S2.2.4 Reporting

All cases of personal injury, while on duty or on museum property, must be immediately reported to the museum safety manager or first available museum authority.

S3.0 Key Safety Rules

- A. **Safety First! Safety is of the first importance in the discharge of duty.*
- B. Obedience to the rules is essential to Safety.
- C. To enter or remain in any service as museum personnel or volunteer is a pledge of willingness to obey the rules at all times.
- D. Cooperation of all personnel in the compliance of these rules is necessary.
- E. The service demands the faithful, intelligent and courteous discharge of duty.
- F. Personnel must be familiar with and comply with applicable Federal, State and other governmental regulations, insofar as they pertain to duties.
- G. Be considerate of others and make sure that the work you are doing does not endanger others.
- H. Rules cannot be written to cover every possible situation that may arise in connection with each task which is associated with your duties. Therefore, it is incumbent upon all personnel to ensure that they safeguard themselves, other personnel, visitors and museum property.

S4.0 General Safety Rules

- A. Personnel whose duties require must provide themselves or have available a copy of these safety rules.

- B. Personnel must be familiar with and obey the safety rules and special instructions insofar as such rules pertain to their duties. If in doubt as to their meaning, they must apply to proper authority for an explanation.
- C. **Safety must be the first consideration in all operations and duties. In all cases, the safest available methods must be followed. In case of doubt or uncertainty, the safe course must be taken.*
- D. Personnel must provide every assistance in their power in carrying out the rules and special instructions, reporting any violation to the proper authority.
- E. ** Always be on the alert for hazardous or unsafe conditions. If they are found, eliminate them; if this can't be done, report them to proper museum authority, warn others and take such steps as necessary to protect the condition until it can be corrected.*
- F. Accidents of any nature, failure in the supply of water or fuel, defects in tracks, bridges, signals or any unusual conditions which may affect operations must be promptly reported to the proper museum authority.

G. **Drugs and Alcohol**

The Museum strives to provide its personnel with a safe, healthy, and productive work environment free from the effects of substance abuse. Abuse of alcohol, drugs, and controlled substances impairs judgment which results in increased safety risks, injuries, and faulty decision-making. It is the policy of the Museum to prohibit the use, consumption, under the influence of, manufacture, sale, transfer, distribution, purchase, or attempts to sell, transfer, distribute, or purchase of any controlled substance or alcohol on or off museum premises, including museum vehicles, or while on duty. This includes personal or Museum-owned vehicles being used for Museum business and vehicles parked on Museum property. Sanctioned museum functions or events are excepted regarding alcohol as outlined and the conditions listed below.

Reporting to work or volunteer under the apparent influence of alcohol, illegal drugs or controlled substances is prohibited. While the Museum reserves the right to determine what symptoms or behaviors may lead to an appearance of being “under the influence”, typically such behaviors could include impaired judgment,

erratic behavior, a strong smell of alcohol, unsteady speech or walk, or other detrimental conduct.

Further, if alcohol is served at a Museum function, it is the responsibility of personnel to limit their consumption so as not to impair judgment or create a safety risk to themselves or others. If any personnel are under the legal age, consuming alcohol at a Museum function is strictly prohibited and will not be tolerated.

At public museum events, all personnel represent the Museum, whether or not they are actively “working” at that event. Therefore, personnel at these events are responsible for maintaining appropriate behavior and not drinking alcohol to excess – you are the face of the Museum and should represent the museum in a responsible manner.

Notice to Museum Manager

Museum personnel must notify the appropriate museum manager and/or volunteer coordinator whenever they are using either a prescription drug including, but not limited to physician approved medical marijuana, or an over-the-counter drug *if use of the drug may potentially affect the personnel’s ability to safely perform their assigned job duties or may otherwise affect the safety of the workplace.* Upon such notification, Colorado Railroad Museum reserves the right to take appropriate steps to preserve the safety of its personnel and the workplace, including, but not limited to, the right to relieve the person of their assigned job duties during the period of usage. Failure to provide the required notification will result in disciplinary action, up to and including termination of employment or volunteering at the museum.

- H. In keeping with the museum’s intent to provide a safe and healthful work environment, museum facilities are tobacco-free environments, and smoking or using tobacco is prohibited. “Museum facilities” are defined as all buildings and areas of use by the museum, the entirety of all buildings where the museum has operations, storage areas, parking lots, and museum grounds. This includes smoking or using tobacco in privately owned vehicles on museum premises. Personnel who choose to use tobacco products must do so on their breaks or meal periods and off museum facilities. Visitors are also expected to adhere to this policy. All personnel share in the responsibility for, adherence to, and enforcement of this policy.
- I. All personnel are required to keep the premises subject to his control in a clean and orderly condition.

Any personnel who is careless of his own Safety or that of others will not be allowed to remain in the service. Personnel must not rely solely upon the carefulness of others, but must protect themselves when their own Safety is involved.

- J. In case of danger to museum property, personnel must unite to protect it and must take every precaution to guard against loss and damage from any cause.
- K. Personnel must exercise care to avoid injury to themselves or others by observing the condition of equipment and the tools which they use in performing their duties, and when found defective, will, if practicable, put them in safe condition, reporting defects to the proper museum authority.
- L. They must inform themselves as to the location of structures or obstructions where clearances are close.
- M. ****Expect the movement of trains, locomotives, cars or other equipment at any time, on any track, in either direction.***
- N. Every precaution must be taken to prevent injury to personnel, and they are prohibited from doing any work in a manner that might jeopardize their Safety.
- O. ****Watch out for museum guests with extra care, assuming they will be preoccupied and unaware of train movements.***
- P. **** Never put any objects (such as coins) on track and discourage visitors from doing so as well.***
- Q. Personnel are expected, during their off time, to obtain ample rest to be physically and mentally fit for the proper and safe performance of their duties.
- R. Team work is essential to Safety. When working in groups, all concerned must understand the moves to be made.
- S. All personnel and volunteers able to do so and whose duties will permit, must observe trains closely and if anything, unusual or defective is noted, such as hot journal, brakes sticking, dragging brake rigging, sliding wheels, fire, lading shifted over side or end of car, protruding objects, swinging car doors, or any other dangerous condition, must make every effort to call the attention of the crew

on the train to such condition. If train is moving, STOP signal must be given. Museum personnel must be notified at once if unable to stop train.

- T. ** Do not cross, or allow guests past the inside perimeter fence during railroad operations. During railroad operations, volunteers and guests are not allowed to pass this area unless accompanied by museum personnel or qualified operating volunteer. Always inquire with museum personnel to determine if there are active railroad operations.*
- U. ** Volunteers must watch out for museum guests with extra care. Assuming they will be preoccupied and unaware of train movements.*
- V. ** Always be courteous with museum guests, DON'T EXCITE! BE POLITE!*

S5.0 Job Safety Briefing

Operations, mechanical and maintenance of way activities are under the control and supervision of the assigned museum personnel or their designee. Before operations begin, museum personnel or their designee will conduct a safety/job briefing with all personnel, that are present. A new briefing will be conducted if new people arrive, or if changes occur to the operating plan or other conditions change. Each operating plan should consider hazards; assign specific responsibilities and an explanation of those assignments.

S6.0 Personal Protective Equipment and Clothing (PPE)

Personal protective equipment for eyes, face, head, and extremities, protective clothing, respiratory devices, and protective shields and barriers, shall be used and maintained in a sanitary and reliable condition.

- A. Personal protective equipment furnished or approved by the museum must be worn or used as prescribed by the rules or special instructions. Personnel must not alter personal protective equipment.
- B. Hand protection should be worn when there is a risk of exposure to harmful substances, punctures, severe abrasions, lacerations or cuts, chemical or thermal burns, high voltage, vibration, temperature extremes, or infectious biological agents.
- C. Where required, safety hats furnished or approved by the museum will be worn while on duty.

- D. Hearing protection (ear plugs/earmuffs) when entering designated hearing protection areas, while performing designated jobs/activities, or in situations where the noise requires an personnel to raise his or her voice during normal conversation at a distance of 3 feet.
- E. Personnel must wear goggles or other suitable eye protection where use of machines, tools, or other work operations presents the hazard of flying objects or liquids. Personnel whose duties require the use of goggles must have them on their person or readily available. Safety glasses must be worn at all times while on duty in shop areas.

Prescribed eye protection, (goggles and/or face shield), properly fitted and kept clean, must be worn when performing work as outlined above and any other time when designated by sign, special instruction or museum authority.

Personnel near enough to be exposed to any operation requiring eye protection must also wear prescribed eye protection.

Use prescribed helmet or hand shield when electric welding or cutting or watching such operations.

- F. Personnel in occupations in which there exists opportunity for foot and ankle injuries or as designated by museum supervisor, must wear shoes of sturdy construction and proper height to insure adequate protection. This footwear will cover the ankle and will be a lace up boot, of approximately 6 inches or more in height with a defined heel and safety toe. Safety shoes must be worn where required by museum personnel.
- G. Except when engaged in welding operations, the wearing of dark lens goggles or glasses at night is prohibited.
- H. Use approved respirator when spray painting or in other work involving fumes or dust. Use approved air supply system if required.

S7.0 General Work Environment

S7.1 Working around Shops and Maintenance

A. Safety Rules for Hand Tools

1. Select the proper size and type of tool for your work. An expert never uses a tool unless it is sharp and in good condition. If tools are broken, have loose handles, or need adjustments find replacements or repair your tool.
2. Do not put away a damaged tool for someone else to find and use. Notify appropriate museum personnel so they can be repaired or replaced.
3. When carrying tools, keep sharp-edged and pointed tools turned down and away from you. Do not swing or raise your arms over your head while carrying tools. Carry only a few tools at one time, unless they are in a special holder. Do not carry sharp tools in the pocket of your clothes.
4. When clamping stock, whenever possible, mount the work in a vise, clamp, or special holder. This is especially important when using chisels, gouges, or portable electric tools.
5. Hold a tool in the correct position while using it. Most edged tools should be held in both hands with the cutting motion away from yourself and others. Be careful when using your hand or fingers as a guide to start a cut. Test the sharpness of a tool with a strip of paper or a scrap of wood. **DO NOT USE YOUR FINGERS.**
6. Do not rush through your work. A steady, unhurried pace is safest and produces the best work.

B. Lifting Safely

1. Plan ahead before lifting. Know what you are doing and where you are going. If lifting with another person make sure of you agree on the plan.
2. When lifting, protect your back muscles when lifting heavy objects. Have someone help you. Lift with your arm and leg muscles. Secure help with long boards, even if they are not heavy.
3. Lift close to your body. Make sure you have a firm hold on the object and keep it balanced.
4. Feet shoulder width apart. Feet too close together or too far apart will be unstable and hinder movement.
5. Bend your knees and keep your back straight. Practice the lifting motion, keep your back straight and keep your spine straight.
6. Tighten stomach muscles & lift with your legs. Your legs are stronger than your back, let them do the work.

7. Don't twist or bend and keep your eyes up. Looking slightly upwards will help maintain a better position of the spine.

C. Housekeeping

1. Keep your materials carefully organized on your bench with tools located near the center.
2. Do not pile tools on top of each other. Never allow edged or pointed tools to extend out over the edge of the bench. Close your vise when it is not in use and see that the handle is turned down. Clean your bench when you are done.
3. The floor should be clear of scrap blocks and excessive litter. Keep equipment and materials you are using out of traffic areas. Immediately wipe up any liquids spilled on the floor.
4. Store and stack your work carefully. If the storage is overhead, be sure the material will not fall off. Straighten the lumber rack when you remove a board. Do not leave narrow strips protruding from the end of the storage rack, especially at or near eye level.

D. Ladder and Scaffold Safety

1. Read and follow all labels/markings on the ladder. Ladders and scaffolding must comply with Federal and State regulations.
2. Avoid electrical hazards! – Look for overhead power lines before handling a ladder. Avoid using a metal ladder near power lines or exposed energized electrical equipment.
3. Always inspect the ladder or scaffold prior to using it. If damaged, it must be removed from service and tagged until repaired or discarded.
4. Do not use a self-supporting ladder (e.g., step ladder) as a single ladder or in a partially closed position.
5. Do not use the top step/rung of a ladder as a step/rung unless it was designed for that purpose.
6. Always maintain a 3-point (two hands and a foot, or two feet and a hand) contact on the ladder when climbing. Keep your body near the middle of the step and always face the ladder while climbing.
7. Only use ladders and appropriate accessories (ladder levelers, jacks or hooks) for their designed purposes.
8. Ladders must be free of any slippery material on the rungs, steps or feet.
9. Use a ladder only on a stable and level surface, unless it has been secured (top or bottom) to prevent displacement.
10. Do not place a ladder on boxes, barrels or other unstable bases to obtain additional height.

11. Do not move or shift a ladder while a person or equipment is on the ladder.
12. An extension or straight ladder used to access an elevated surface must extend at least 3 feet above the point of support (see diagram). Do not stand on the three top rungs of a straight, single or extension ladder.
13. The proper angle for setting up a ladder is to place its base a quarter of the working length of the ladder from the wall or other vertical surface (see diagram).

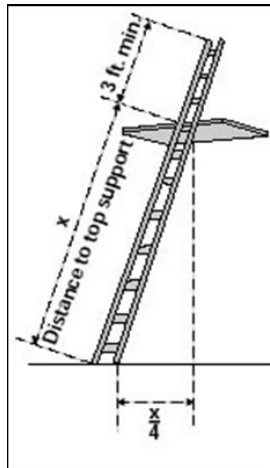

14. A ladder placed in any location where it can be displaced by other work activities must be secured to prevent displacement or a barricade must be erected to keep traffic away from the ladder.
15. Be sure that all locks on an extension ladder are properly engaged.
16. Do not exceed the maximum load rating of a ladder. Be aware of the ladder's load rating and of the weight it is supporting, including the weight of any tools or equipment.
17. Placing ladder on track, unless proper protection is provided, is prohibited. Arrange with museum personnel or person in charge for blue signal protection as outline in Safety Rule S8.0 and Operating Rule 4.8.
18. Provide proper fall protection in applicable situations if a ladder or scaffold is not available or practical.

E. Safety Rules for Power Equipment, General

Before operating any power tool or machine you must be-come thoroughly familiar with the way it works and the correct procedures to follow in its use. As you learn to use a machine the correct way, you will also be learning to use it the safe way.

Know and understand the general safety rules that apply to power machine operation. You must also familiarize your-self with the specific safety rules that

apply to each machine. You must demonstrate to applicable museum supervision that you can use the machine correctly and safely.

1. Wear appropriate clothing. Remove coats or jackets, and roll up loose sleeves. Remove jewelry.
2. You must be wide awake and alert. Never operate a machine when you are tired or ill.
3. Think through the operation before performing it. Know what you are going to do and what the machine will do.
4. Make all the necessary adjustments before turning on the machine.
5. Never remove or adjust a safety guard without consulting museum supervision.
6. Use approved push sticks, push blocks, feather boards, and other safety devices. Some operations may require the use of a special jig or fixture.
7. Keep the machine tables and working surfaces clear of tools, stock, and project materials. Also keep the floor free of scraps and excessive litter.
8. Allow the machine to reach its full operating speed before starting to feed the work.
9. Feed the work carefully and only as fast as the machine will easily cut.
10. Maintain the MARGIN OF SAFETY specified for the machine. This is the minimum distance your hands should ever come to the cutting tool while in operation. Never allow your hands to be in a direct line with the cutting blade.
11. If a machine is dull, out of adjustment, or not working properly, shut off the power and inform the project lead or the shop foreman or other museum personnel member.
12. When you are operating the machine, you are the only one to control it. Start and stop the machine yourself. If someone is helping you, be sure they understand that they are expected to know what to do and how to do it.
13. Do not allow your attention to be distracted while operating a machine. Also, be certain that you do not distract the attention of other machine operators.
14. Stay clear of machines being operated by others. See that others are out of the way when you are operating a machine.
15. When you have completed an operation on a machine, shut off the power. Wait until it stops before leaving the machine or setting up another cut. Never leave a machine running while unattended.
16. Machines should not be used for trivial operations, especially on small pieces of stock.
17. Do not crowd around or wait in line to use a machine. Ask the present operator to inform you when they are finished. Common standards of courtesy

may slow you down, but they will make the shop a safer and more pleasant place to work.

18. Do not distract the machine operator.

F. Safety Rules for Lathes & Milling Machines & Large Drill Press

1. **Only preapproved operators to use Lathes & Milling Machines.** Before starting the machine, be sure that the work is securely clamped and there is proper clearance for the rotating stock.
2. Wear goggles or a face shield to protect your eyes.
3. Select turning speed, feed speed and drilling speed and RPM carefully. Large diameters must be turned at the lower speed.

G. Safety Rules for Table Saws

1. Be certain the blade is sharp and the right one for your work.
2. Set the blade so it extends no more than 1/8" above the stock to be cut.
3. Stand to one side of the operating blade and do not reach across it.
4. Maintain a 4-in. margin of safety. Clamp a small piece of stock to a larger piece to cut safely.
5. Stock should be surfaced, with at least one edge jointed before being cut on the saw.
6. The position of the stock must be controlled either by the fence or the miter gauge. **NEVER CUT STOCK FREE HAND.**
7. Use extra caution if you are using stock that has knots, splits or is warped.
8. Stop the saw before making adjustments to the fence or blade.
9. Do not let small scrap cuttings accumulate around the saw blade. Use a push stick to move them away.
10. When you complete your work, turn off the machine and remain until the blade has stopped. Lower the saw blade below the surface of the table, clear the saw table and place waste cuttings in the scrap box.

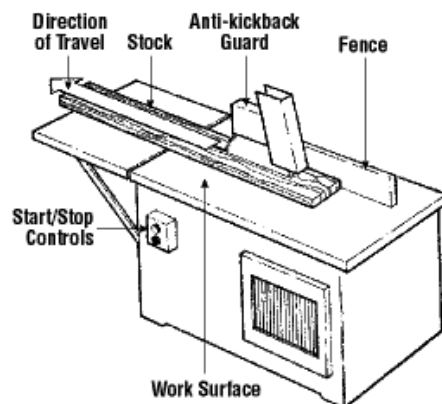

H. Safety Rules for Radial Arm Saws

1. Stock must be held firmly on the table and against the fence for all crosscutting operations. The ends of long boards must be supported level with the table.
2. Before turning on the motor be certain that all clamps and locking devices are tight and the depth of cut is correct.
3. Keep the guard and anti-kickback device in position.
4. Always return the saw to the rear of the table after completing a crosscut or miter cut. Never remove stock from the table until the saw has been returned.
5. Maintain a 6-inch margin of safety.
6. Shut off the motor and wait for the blade to stop before making any adjustments.
7. Be sure the blade is stopped before you leave the machine.
8. Keep the table clean and free of wood scraps and excessive amounts of sawdust.
9. Do not rip stock on the radial arm saw. Use the table saw.

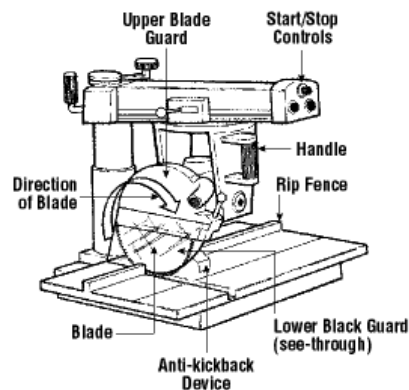

I. Safety Rules for Band Saws

1. Wheel guard doors must be closed, and the blade properly adjusted, before turning on the machine.
2. Adjust the upper guide assembly so it is $\frac{1}{4}$ in. above the work
3. Allow the saw to reach full speed before feeding the work.
4. The stock must be held flat on the table.
5. Feed the saw only as fast as the teeth can easily re-move the wood.
6. Maintain a 2-inch margin of safety.
7. Plan saw cuts to avoid backing out of curves when-ever possible.
8. Make turns carefully and do not cut radii so small that the blade is twisted.
9. Stop the machine before backing out of a long, curved cut.

10. Round stock should not be cut unless mounted securely in a fixture or hand screw.
11. If you hear a clicking noise, turn off the machine at once. This indicates a crack in the blade. If the blade breaks, shut off the power and move away from the machine until both wheels stop.
12. Turn off the machine as soon as you have finished your work. Do not leave the machine until it has stopped running.

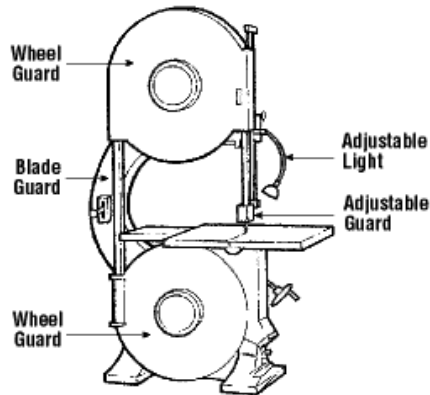

J. Safety Rules for Shaper

The shaper is the most dangerous tool in the wood shop!

1. Ensure cutters are properly mounted.
2. Unplug machine when installing and breaking down any cutter setup or fence adjustment.
3. A face shield is required during cutting operations
4. Keep hands a minimum of 4 inches away from cutters.
5. Keep hold downs properly adjusted
6. Do not force material through the cutters.
7. Properly support long material. Short pieces must be at least 8" long.
8. Use a miter gauge when cross cutting.

K. Safety Rules for Jointer

1. **Only previously checked out individuals may operate this machine.**
2. Before turning on the machine, make adjustments for depth of cut and position-never more than is comfort-able when cutting.
3. NEVER run your hands across the cutting blades.

4. The maximum cut for jointing an edge is 1/8 inch; for a flat surface, 1/16 inch.
5. Stock must be at least 3/8-inch-thick, unless a special feather board is used.
6. Feed the work so the knives will cut with the grain. Use only new stock that is free of knots, splits, and checks.
7. Keep your hands away from the cutter head even though the guard is in position. Maintain at least a 4-in. margin of safety!
8. Use a push block when planing a flat surface. Do not plane end grain unless the board is at least 12 in. wide.
9. The jointer knives must be sharp. Dull knives will vibrate the stock and may cause a kickback.

L. Safety Rules for Chop Saw

1. Make sure all material is tight against the fence and supported level with the table. Never cut unsupported stock.
2. Keep hands at least 4 inches from the blade.
3. Do not cut cross armed. Never reach across your hand (arm) when cutting.
4. When cutting round stock use clamps to keep stock from being rotated by the blade.
5. Always bring the blade to the outside of the stock and cut in. Never pull the blade towards you while cutting.
6. Never use a dull blade.

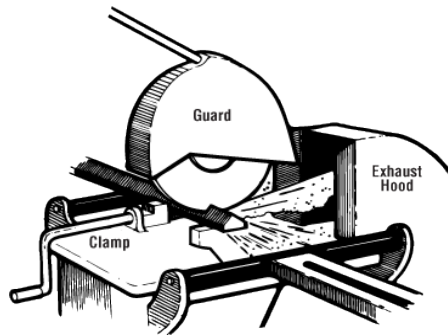

M. Safety Rules for Stationary Grinders

1. Wear a full-face shield and separate eye protection.
2. Make sure that the tool support is not more than 1/8" away from wheel at any time.
3. Never force material into the wheel
4. Do not grind on the sides of the wheels.

5. Do not grind aluminum.
6. The tool grinder will only be used to sharpen tools.

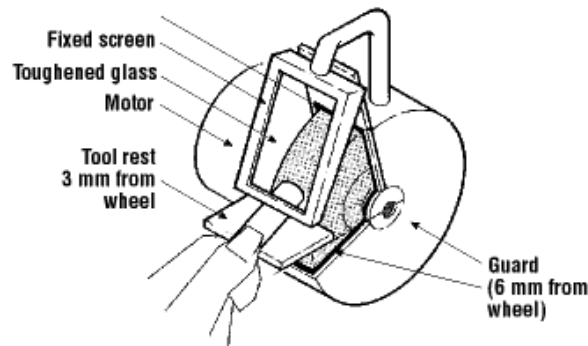

N. Safety Rules for Saber Saws

1. Select the correct blade for your work and be sure it is properly mounted.
2. Disconnect the saw to change blades or make adjustments.
3. Place the base of the saw firmly on the stock before starting the cut.
4. Turn on the motor before the blade contacts the work.
5. Do not attempt to cut curves so sharp that the blade will be twisted.
Follow procedures described for band saw operation.
6. Make certain the work is well supported. Do not cut into sawhorses or other supports.

O. Safety Rules for Portable Circular Saws

1. Stock must be supported in such a way that the kerf will not close and bind the blade during the cut or at the end of the cut. Always clamp the work to be cut.
2. Thin materials should be supported on benches. Small pieces should be clamped in a vise or onto a bench top or sawhorse.
3. Be careful not to cut into the bench, sawhorse, or other supporting devices.
4. Adjust the depth of cut to the thickness of the stock, and add about 1/8 inch.
5. Check the base and angle adjustment to be sure they are tight. Plug in the cord to a grounded outlet and be sure it will not become fouled in the work.
6. Always place the saw base on the stock, with the blade clear, before turning on the switch.
7. During the cut, stand to one side of the cutting line.
8. Large saws will have two handles. Keep both hands on them during the cutting operation. Small saws should also be guided with both hands when possible.
9. Always unplug the machine to change blades or make major adjustments.

10. Always use a sharp blade with plenty of set.

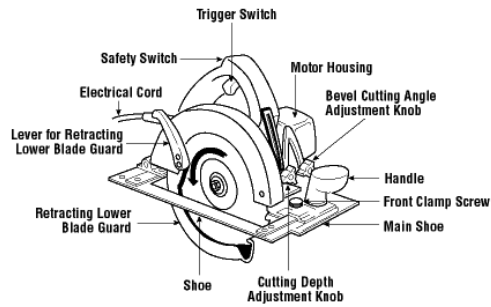

P. Safety Rules for Planers

1. **Only previously checked out individuals may operate this machine.**
2. Adjust the machine to the correct thickness of cut before turning on the power.
3. Stock should be at least 12 in. long, or several inches longer than the distance between the centers of the feed rolls.
4. Surface only lumber that is free of loose knots and serious defects. Examine lumber for nails or other things that may damage the blade.
5. Plane with the grain, or at a slight angle with the grain. Never attempt to plane cross grain.
6. Stand to one side of the work being fed through the machine.
7. Do not look into the throat of the planer while it is running.
8. Do not feed stock of different thicknesses side by side through the machine.
9. Handle and hold the stock only in an area beyond the ends of the table.
10. If the machine is not working properly, shut off the power at once and inform the shop foreman or other museum personnel member.

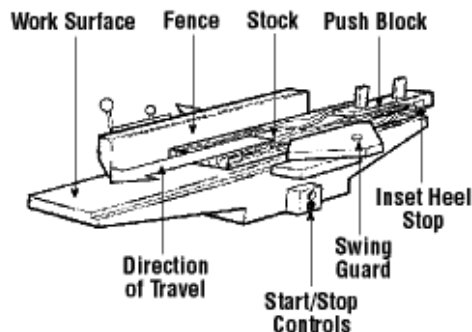

Q. Safety Rules for Sanding Machines

1. Be certain the belt or disc is correctly mounted. The belt must track in the center of the drums and platen. Do not operate the disc sander if the abrasive paper is loose.
2. Check the guards and table adjustments to see that they are in the correct position and locked securely in place.
3. Use the table, fence, and other guides to control the position of the work, whenever possible.
4. Small or irregular-shaped pieces should be held in a hand clamp, or a special fixture.
5. When sanding the end grain of narrow pieces on the belt sander, always support the work against the table.
6. Sand only on the side of the disc sander that is moving toward the table. Move work along this surface so it will not burn.
7. Always use a pad or push block when sanding thin pieces on the belt sander.
8. Do not use power sanders to form and shape parts when the operations could be better performed on other machines.
9. Sand only clean new wood. Do not sand work that has excess glue or finish on the surface. These materials will load and foul the abrasive.

R. Safety Rules for Drill Presses

1. Check the speed setting to see that it is correct for your work. Holes over $\frac{1}{2}$ in. should be bored at the lowest speed.
2. Use only an approved type of bit. Bits with feed screws or those with excessive length should not be used.
3. Mount the bit securely to the full depth of the chuck and in the center. Remove the key immediately.
4. Position the table and adjust the feed stroke so there is no chance of the bit hitting the table.
5. The work should be placed on a wood pad when the holes are drilled all the way through.
6. Work that will be held by hand should be center punched.
7. Small or irregular shaped pieces must be clamped to the table or held in some special fixture.
8. Feed the bit smoothly into the work. When the hole is deep, withdraw it frequently to clear the shavings and cool the bit.
9. Always clamp metal stock for drilling. Never hold with your hands.

S. Safety Rules for Portable Electric Drills

1. Select the correct drill or bit. Mount it securely to the full depth of the chuck.
2. Either clamp a scrap piece under work to prevent splintering the underside, or drill from both sides.
3. Stock to be drilled must be held in a stationary position so it cannot be moved during the operation.
4. Connect the drill to a properly grounded outlet.
5. Turn on the switch for a moment to see if the bit is properly centered and running true.
6. With the switch off, place the point of the bit in the punched layout hole.
7. Hold the drill firmly in one or both hands and at the correct drilling angle.
8. Turn on the switch and feed the drill into the work. The pressure required will vary with the size of the drill and the kind of material.
9. During the operation, keep the drill aligned with the direction of the hole.
10. When drilling deep holes, especially with a twist drill, withdraw the drill several times to clear the shavings.
11. Follow the same precautions and procedures as when drilling holes with the drill press.

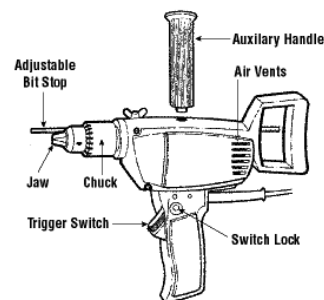

T. Safety Rules for 8-Ton Electric Hoist

1. Only one person to operate hoist control and one person to give signals if hoist operator cannot directly view hoisting operation.
2. Rig item to be hoisted securely. Do not use damaged slings or chains.
3. Stand clear during hoisting operations. If you are not involved in the hoisting operation move out of the area.
4. Always use a safety stand wider than the project being raised.

U. Turntable and Inspection Pits

1. Personnel must not get on or off turn tables in motion. Personnel must not occupy track portion of turntable when movement is being made. Do not insert locking device in turntable until table is stopped.

2. Covers, where provided, must not be left off drop pits or inspection pits without proper protection.
3. Keep a safe distance from edge of inspection, turntable, or other pits except when necessary for the purpose of inspection, maintenance or use.
4. Engines must not be moved on or off turntable until rails are in proper alignment and table securely locked.
5. Movement of locomotive toward turntable without proper alignment and locking of turntable is prohibited.

S7.2 Working around Museum and Moving Equipment

A. Office and Library

1. All personnel shall be familiar with the location and use of fire extinguishers and fire exits. Keep all emergency pathways, exits, electrical boxes and locations of fire extinguishers clear.
2. Do not attempt to lift or move bulky or heavy equipment or materials alone, get someone to assist.
3. Contents of filing cabinets shall be arranged so as not to overbalance cabinet. Contents must be distributed through the entire cabinet rather than in top drawer.
4. Store heavy objects close to the floor, and do not exceed the load capacity of shelves or storage units.
5. Allowing filing, desk, or cabinet drawers to remain open is prohibited.
6. Caution must be used in operating paper cutters, trimmers, and power punches. Keep fingers clear of the cutting blades. Blade of paper cutters must not be left open after use.
7. Report any sharp edges, splinters, or defective parts on office furniture or equipment so repairs can be made.
8. Telephone or electrical cords in walking areas must be encased by floor molding or appropriate flooring tape to avoid creating a tripping hazard.
9. Keep all extension cords away from heat sources.
10. Do not overload electrical circuits.
11. To avoid spills or burns, use a tray for carrying coffee or hot liquids in cups for any distance. Take time to wipe up spills.
12. Personnel must exercise great care when scooting across floors in caster equipped chairs. Standing on chairs is not allowed.

B. Shop and Shop Area

1. Before moving locomotives or cars on repair tracks or in shops, jacks, portable scaffolds and other devices used in making repairs must be removed a sufficient distance from the track to clear men on side or end of equipment.
2. Cars left standing on repair or shop tracks must have sufficient hand brakes set or wheels chocked to prevent movement. Locomotives will be chained or blocked as appropriate.
3. Air brakes must not be operated on locomotives or cars undergoing repairs without first knowing that no one will be caught. Before performing any work on car trucks or foundation brakes, care must be exercised to see that air brakes are cut out and auxiliary reservoir is bled.
4. When required to perform work on cars or locomotives, necessary protection as specified by Operating Rule 4.8 and Safety Rule S8.0 (Blue Signal Protection) must be provided.
5. Mounted wheels must always be pushed, never pulled.
6. Stepping or jumping across inspection pits is prohibited.

C. Jacks and Jacking Rolling Equipment

1. To leave rolling wheels, mounted or unmounted, before they are stopped and properly blocked is prohibited. Before a pair of mounted wheels is rolled from stock on a wheel track, the next out pair must be blocked.
2. Before jacking up end of car, locomotive, tender, locomotive crane, etc., wheels on other end of such equipment must be carefully blocked or chained to prevent same from moving. Locomotive brakes must be released. No one may occupy cars while being jacked. All personnel must stand clear of equipment being jacked.
3. Jacks in bad order must not be used. Jacks must not be used metal to metal; a piece of wood or approved cushioning material must be placed between the head of jacks and the metal to prevent slipping. Good blocking must be used under the jack and must be carefully placed and level to avoid tipping from under the load. Be sure that the jack is of sufficient capacity for the work to be done. Remove handles when jacks are not being operated. Keep out of path traveled by jack handle.
4. Under no circumstances may jacks be left standing under load in roundhouse, shop or on repair tracks, without support of trestles, horses or blocks. When necessary to remove or replace trucks under cars, personnel must not go under car to hold up center pin by hand while truck is rolled or centered, but must use tongs or slide plate for supporting pin.

5. When applying or removing wedges and brasses on cars or locomotives, care must be taken to avoid injury to hands. The wedge must be removed with feeler hook and the brass removed by lifting over journal collar and placing fingers under both edges of brass at extreme front corners. In applying brass, reverse the operation.
6. When preparing to check a suspected hot journal (hot box), never open the journal box lid if it is smoking unless precautions are taken to avoid injury and extinguish fire in case the hot oil should flash into flame.

D. Switches

1. The position of switches or derails is the responsibility of the person using them.
2. All loop track switches must be lined and locked for loop track movement except when being used for switching over them.
3. All derails must be left lined and locked in the derailing position except when operating over them.
4. Keep all parts of body clear of switch lever travel to avoid being struck.
5. Be sure of secure footing before exerting stress on a switch stand lever. To avoid injury, brace body firmly, avoid twisting body, and exert a steady pull on lever.
6. When the position of the switch is to be changed behind moving equipment, personnel must not attempt to operate the switch until entire movement is clear of the switch. When practicable, the personnel attending the switch must stand on the opposite side of the track from the switch stand, or at least 20 feet away from the switch stand while waiting for the movement to clear the switch.
7. Personnel must check switch points after lining switches to be certain they are properly lined, and then give signal to operator or engineman.
8. Train and engine crew as well as operators must observe to verify that switches and derails are properly lined for their movement.

E. Tracks and Equipment

1. Placing equipment, tools, grease, hoses, or cords on a platform or walkway where it will constitute a tripping or slipping hazard, or where it may be struck by a train or riding on the side of a car is prohibited.
2. Placing tools, clothing, or other equipment on ladder rungs, hand holds, footboards, running boards or steps is prohibited when equipment is subject to movement and lacking blue signal protection.

3. When on equipment, watch and be prepared for sudden starting, stopping, lurch or sudden jerk.
4. ****Do not step on top of a rail, step over it and be alert for wet and slippery conditions. Walking, sitting, stepping on frog, rail, switch or guard rail is prohibited.***
5. ****Never stand in the middle of a track. Always stand at least 20 feet away from tracks used during operations. Personnel must avoid standing or walking on or near the tracks except in the performance of duty.***
6. Walking through escaping steam which obscures the vision is prohibited.
7. Leaning or standing against cars or locomotives is prohibited, unless necessary in the performance of duty and protection has been provided as prescribed by Rule 64.
8. ****Do not go in-between or underneath equipment or allow museum guests to go in-between or underneath equipment. Sitting, lying, or crossing under cars is prohibited, except when required in the performance of duty and then only when proper protection is afforded.***
9. Face locomotive, car or ladder when getting on or off, use both hands, have secure handhold and firm footing. Always provide 3 point protection. Carrying tools, material or any object which prevents secure hold or interferes with safe movements while climbing is prohibited.
10. ****Do not climb on or allow museum guests to climb onto equipment that is not equipped with stairs or other devices that will safely allow entry.***
11. Be alert for under foot conditions and avoid objects, obstructions, holes and openings that may contribute to tripping, slipping or turning ankle.
12. Before operating sliding side door on car, be certain that door is properly tracked and safety devices are in place.
13. While opening or closing car doors, keep fingers clear of edge of jamb of door, casting or rail on which door travels.
14. Throwing or dropping material when it is likely to cause injury is prohibited.
15. Only persons authorized by museum personnel will operate engines, cranes, vehicles or machines of any kind. Unauthorized persons must not be permitted on these machines nor distract personnel operating them.
16. Before going between standing locomotives or cars, personnel must wait until slack is adjusted and have proper understanding with other personnel to guard against an unexpected move, and know there is no danger from approaching cars or locomotives.
17. Giving signal to move locomotive or car while any personnel are between cars or locomotive and cars is prohibited.

18. Cars must not be uncoupled except with pin lift lever. If lever is inoperative, have proper understanding and full protection before lifting pin by other means. Operating uncoupling lever on car or locomotive while riding another car or locomotive is prohibited.
19. Stepping in front of moving locomotive or cars to adjust coupler or knuckle or using foot or hand to adjust them from any position when they are about to come together is prohibited.
20. Before uncoupling automatic brake air hose by hand, have both angle cocks closed and firm hold on both hoses.
21. Before reducing brake pipe pressure with angle cock, hold the lower end of the hose firmly.
22. Leaning beyond side of moving passenger cars to observe and check for malfunctions is prohibited. Use good judgment in determining if the train must be stopped to inspect equipment.
23. Secure vestibule gates, chains, and cross-over plates in raised and hooked position before uncoupling or separating passenger equipment.
24. Appliances used in taking supplies of fuel, water or sand must not be moved until locomotive is properly placed and brakes applied. After servicing of locomotive is completed, appliances must be replaced and secured in a position clear of tracks before locomotive is moved.
25. Before leaning beyond side of locomotive, look in both directions for trains, locomotives or cars on adjacent track and structures or obstructions alongside of tracks.
26. When on the steps or catwalk of a locomotive, maintain secure hand hold. Always provide 3-point protection

S7.3 On or Near Tracks, Locomotives and Rail Cars

- A. Going Between Cars or Locomotives
 1. Before crew members go between or work on the end of rail equipment on any track, they must:
 1. Wait for movement to stop and slack to adjust.
 2. Ensure that all crew members have a clear understanding of the work to be performed.
 2. Where engines may be working at both ends of a track or tracks, crews switching must have a clear understanding of movements to be made.
 1. If a locomotive is not coupled to the rail equipment but on same track:

- A crew member must notify all members of the crew verbally or by radio that the crew member will be going between or working on the end of rail equipment on any track.
 - Members of the notified crew must acknowledge verbally or by radio that they understand a crew member will be going between or working on the end of rail equipment.
2. If a locomotive is coupled to the rail equipment:
- After ensuring movement has stopped and slack has adjusted, the crew member must either announce by radio, “Going between,” or give the prescribed hand signal.
 - The crew member at the controls of the locomotive must fully apply the independent brakes, center the reverser, and then acknowledge the radio transmission or the hand signal:
 - If using a radio response, acknowledge, “Set and centered.”
 - If using hand signals, sound one long whistle signal.
 - The brakes must remain applied with the reverser centered or removed, and the locomotive must not be left unattended until the crew member requesting protection gives a radio or hand signal to move or announces by radio, “In the clear.”
3. When crew members are going between or working on the end of equipment:
- Controls or devices (automatic brake valve, hand brake, brake cylinder release valve, etc.) that could affect movement of that equipment must not be operated without permission from the crew member(s) going between or working on the end of the equipment.
 - Other rolling equipment must not strike, couple into or affect movement of the equipment the crew member(s) is working on the end of or going between.
4. Do not go between uncoupled locomotives or cars when clearance between them is less than 10 feet except when you have exhausted all practical means of complying with the 10 feet requirement. In addition to complying with the other applicable portions of this rule, personnel going between with less than 10 feet of separation must:
- Ensure equipment is secure against undesired movement.
 - Keep at least one foot outside the rail, when practical.
 - Refrain from placing all or part of their body directly between coupling devices unless necessary to complete the work.

- Obtain 20 feet of separation between the uncoupled locomotives or cars as soon as the equipment can be positioned practically and safely.

B. Locomotives

1. Only authorized persons are permitted to move locomotives. The movement of locomotives in and around engine house with less than two people is prohibited. One person must be in a position to protect the direction of movement at all times. It is permitted for engine watchmen to move from the ash pits to the coal dock after checking around the locomotive carefully.
2. Suitable warning must be given before locomotives are moved.
3. The movement of locomotive without sufficient main reservoir pressure for adequate braking is prohibited.
4. Before leaving locomotive unattended, be sure locomotive is blocked or chained, engine brakes are set, and cylinder relief valves (snifters) are open.
5. Engine house doors must be opened and properly secured when moving locomotives into or out of engine house. Movement must be made at a safe and slow speed. Suitable warning must be given upon entry or exit. Awnings, wing windows, and cinder trap must be positioned to clear all obstructions.
6. Before moving locomotives on service tracks, into or out of engine house, inspection must be made to determine that all are in a safe position and clear for movement, and that all service hoses, lines, cords, or other devices are disconnected from locomotives and track is clear.
7. Locomotive cab, running boards, grab irons and gangways must be kept free from oil, grease, rags, tools and other objects.
8. Do not enter or permit others to enter boilers, tenders or other confined space without proper training and confined space procedures. Verify all boiler washout plugs are removed and appropriate ventilation is provided before entering boiler. Another Personnel must be present outside the tank opening.
9. Valves, caps, plugs, couplings or other parts of pressure lines, boilers or other containers must not be disturbed while that portion of such line, boiler or other container is under pressure.

C. Hand Brakes

1. Use of non-standard brake clubs or the use of a standard brake club cracked or dangerously worn is prohibited.
2. Before applying stress on brake club, test it to determine that it is in firm position in wheel.

3. When equipment permits, stress on horizontal brake wheel, with or without club, must be toward the car, rather than away from it.
4. While releasing brakes equipped with release controlled by lever or other such device, keep all parts of body clear of movable parts of brake.
5. Using any part of an adjacent car for foot rest when applying or releasing brake is prohibited.
6. In releasing a tight hand brake with or without a club, the pawl must not be forced from the ratchet. If unable to release brake with a steady stress, charge brake system and apply brake or secure help.
7. Where possible, personnel operating hand brake should position themselves so as to afford themselves a view of approaching or standing cars, or anything that may require the movement to be stopped.
8. If moving equipment that does not have a working hand brake or it is not safe to access the brake wheel, use wheel chocks to prevent movement.

D. Getting on and off equipment

1. Getting on or off moving equipment is prohibited, except to avoid personal injury.
2. Getting between cars in motion to couple or uncouple them, adjusting knuckles with the foot, hand or brake clubs is prohibited.
3. When about to board or alight from standing cars or locomotives, look out for trains approaching on adjacent tracks and see that there are no obstructions or openings on the ground and no side obstructions which might cause injury.
4. Have secure handhold when getting on or off locomotives or cars. Always provide 3-point contact.
5. When getting off standing locomotives or cars, retain handhold until foot is firmly placed on the ground or other support. Always provide 3-point contact.
6. Do not carry lunch boxes, tools, grips or other articles in a manner that will interfere with free and safe movement when boarding or alighting from cars, locomotives or cabooses.
7. Getting on or off locomotives and cars by means other than steps, ladders and hand holds provided for the purpose is prohibited. Get off at side of car if possible.
8. When using steps of locomotives, getting off top of car equipped with vertical steps or ladders, or stepping to brake platform, face the equipment and place ball of foot firmly on step, ladder, or brake platform before placing weight on foot.
9. Personnel must face the equipment when descending ladders on cars or steps on locomotives and must observe if footway is clear.

- E. Riding on Locomotives and Cars
 - A. Jumping from passenger or freight car to locomotive while train is moving is prohibited.
 - B. Personnel riding on the outside of equipment must maintain lookout in the direction of movement to avoid coming into contact with structures alongside or over track, or with cars, locomotives or trains on adjacent track. When vision is obscured and not sure of location, stay in the clear.
 - C. When riding in or on moving equipment, be on guard against possible injury from sudden stop or movement. Always provide 3-point contact.
 - D. Except when necessary in the performance of duty, personnel must not ride on tender decks, catwalks, ladders, steps, or tops of moving locomotives.
 - E. Sitting or riding on hand rails, uncoupling levers, or couplers of locomotives or cars is prohibited.
 - F. Riding between cars at any time is prohibited.
 - G. After giving a signal to stop, stepping on track between or in front of locomotive or cars before such stop is made is prohibited.
 - H. Train or engine service personnel are prohibited from riding or walking on the roof of any moving car or caboose. Other personnel whose duties require them to occupy the roof of a car or caboose may do so only when equipment is standing.
 - I. When riding on locomotives or cars, sit or stand in a safe position and do not permit legs or arms to protrude over sides or ends.
 - J. Do not climb over or under couplers, or underneath standing cars or trains, except in the necessary performance of duty, and only then when proper safeguards are provided.
 - K. When necessary to climb through standing coupled cars, do not step on uncoupling lever nor place hands feet or other parts of body between coupler horn and end sill of car. Climbing over couplers of moving cars or underneath moving cars is prohibited.
 - L. Use caution when opening or closing doors on engines, cars, or other equipment.

S7.4 Steam Locomotive Safety

- A. Water glasses and gauge cocks.
 - 1. Close top and bottom gauge glass valves and open gauge glass blow down valve before wiping or cleaning gauge glass
 - 2. Tightening water gauge glass packing nuts, when under steam pressure is prohibited.
 - 3. Engineman must test water glasses and gauge cocks at the beginning of each tour and when conditions require. Procedure for testing water sight glass:

- Close top steam valve feed to water glass from boiler
- Open drain cock and verify that water fills the glass
- Close drain cock
- Open top steam valve to water glass from boiler
- Close bottom water valve feed to water glass from boiler
- Open drain cock and verify that steam fills the glass
- Close drain cock
- Open bottom water valve feed to water glass from boiler

B. Hydrostatic lubricators

1. All steam, water and oil valves must be shut off before attempting to fill with steam oil.
2. When removing hydrostatic lubricator caps, drain must be opened first to relieve internal pressure. Open caps slowly, do not expose face to opening, and avoid escaping steam or oil. Make sure all steam pressure is released before removing oil fill plug.
3. Tightening lubricator glass packing nuts, when under steam pressure is prohibited.

C. Fueling, Watering and Servicing

1. While locomotives are being fueled, watered, or sanded, personnel must station themselves where they will not be struck by fuel, water or sand hose, or might otherwise be injured in case of unexpected movement of locomotive.
2. Locomotive brakes must be applied while taking coal, water or sand.
3. Appliances used in taking supplies of fuel, water or sand must not be moved until locomotive is properly placed and brakes applied. After servicing of locomotive is completed, appliances must be replaced and secured in a position clear of tracks before locomotive is moved. Extreme care must be used not to spill oil on ground or platform.
4. Coal must not be loaded on tender in such manner that it will fall off sides or in gangway of locomotive.
5. Close the valve and drain the spout of water tank or stand pipe before removing spout from manhole of tender or auxiliary tank.
6. Close tender water hatch immediately after taking water.
7. Locomotive cab floor, apron, gangway and gangway steps must be kept free of coal and oil.
8. Shaker bar must be securely placed on lever post and firm footing obtained before shaking grates.

D. Squirt Hose

1. Squirt hose on locomotive must not be left in a position where it may be mistaken for a handhold.
2. Before starting injector, make sure the squirt hose valve is closed off completely, and that personnel are clear of injector overflow exhaust.
3. Caution must be exercised when operating locomotive squirt hose. Squirt hose should never be pointed in the direction of any person or part of the body. Keep secure footing and a firm hold on hose. Avoid using oily or wet gloves.

E. General

1. Keep body and feet in a position where they will not be caught between locomotive cab and tender or between apron and tender when locomotive is in curves.
2. Climbing up or down rear ladder or moving about on rear of locomotive tank while locomotive is backing is prohibited.
3. Personnel are prohibited from using the blow down valves in a manner that might cause injury to people or damage to property.
4. When necessary to relieve cylinder steam pressure manually, push the snifter down with the sole of a good boot while standing on the running board, or by using a board at least 4 feet long.

S8.0 Blue Signal Protection of Workman

This rule outlines the requirements for protecting railroad workmen who are inspecting, testing, repairing, and servicing rolling equipment. In particular, because these tasks require the workmen to work on, under, or between rolling equipment, workmen are exposed to potential injury from moving equipment.

As used in this rule, the following definitions apply:

Workmen

Museum personnel assigned to inspect, test, repair, or service railroad rolling equipment or components, including brake systems. Train and yard crews are excluded, except when they perform the above work on rolling equipment not part of the train or yard movement they are handling or will handle.

- “Servicing” does not include supplying cabooses, engines, or passenger cars with items such as ice, drinking water, tools, sanitary supplies, stationery, or flagging equipment.
- “Testing” does not include personnel making visual observations while on or alongside a caboose, engine, or passenger car.

Group of Workmen

Two or more personnel who work as a unit under a common authority and communicate with each other while working.

Rolling Equipment

Engines, Motors (Geese), cars, and one or more engines coupled to one or more cars.

Blue Signal

During the day, a clearly distinguishable blue flag or light, and at night, a blue light. The blue light may be steady or flashing.

The blue signal does not need to be lighted when it is attached to the operating controls of an engine and the inside of the engine cab area is lighted enough to make the blue signal clearly distinguishable.

Effective Locking Device

When used in relation to a manually operated switch, derail, or turntable a lock that can be locked or unlocked only by the individual or group of workmen applying the lock.

Engine and Car Shop Repair and/or Service Area (Roundhouse)

One or more tracks within an area where engine and/or rolling equipment testing, servicing, repairing, inspecting, or rebuilding is performed. All tracks east of the main road crossing on the roundhouse lead are considered an Engine and Car Repair and/or Service Area.

Switch Providing Direct Access

A switch that if used by rolling equipment could permit the rolling equipment to couple to the equipment being protected.

A. What a Blue Signal Signifies

A blue signal signifies that *workmen are on, under, or between rolling equipment* and requires that:

1. Rolling equipment must not be coupled to or moved, except as provided for movement in “Engine and Car Repair and/or Service Area (Roundhouse) of this rule (Part E).

2. Rolling equipment must not pass a blue signal on a track protected by the signal.
3. Other rolling equipment must not be placed on the same track so as to block or reduce the view of the blue signal.
4. Rolling equipment must not enter a track when a blue signal is displayed at the entrance to the track.

Blue signals must be displayed for group of workmen who will work on, under, or between rolling equipment.

Protection Removed. Blue signals may be removed only by the individual or group who placed them. When blue signal protection has been removed from one entrance of a double- ended track or from either end of rolling equipment on a main loop track, that track is no longer under blue signal protection.

B. How to Provide Protection

Note: All CRRM operating personnel performing mechanical work that requires blue signal protection will also display their personal identification tag or “check” to the blue signal displayed so as to identify who initially placed the blue signal and identify those working under this specific blue signal protection.

When workmen are on, under, or between rolling equipment and exposed to potential injury, protection must be provided as follows:

On Main Loop Track. A blue signal must be displayed at each end of the rolling equipment. (See Figure 3)

On Auxiliary Track. One of these three methods of protection or a combination of these methods must be provided:

1. Each manually operated switch must be lined and locked against movement onto the track. A blue signal must be placed at or near each such switch.

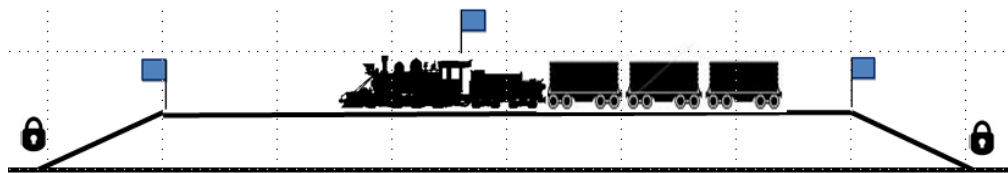

(Figure 1)

2. A derail capable of restricting access to the track where work will occur must be locked in derailing position and:

a. Positioned at least 20 feet from the rolling equipment to be protected.

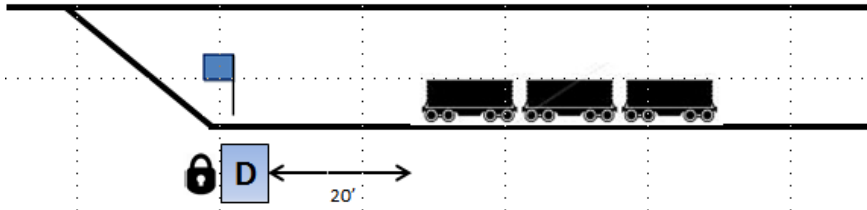

(Figure 2)

or

b. Positioned at least 20 feet from the end of rolling equipment on a Engine and Car Repair and/or Service Area where speed is limited to not more than 5 MPH. A blue signal must be displayed at each derail.

C. Blue Signal Readily Visible to Engineer

In addition to providing protection as required in “On a Main Loop Track” and “Auxiliary Track,” when workmen are on, under, or between an engine or rolling equipment coupled to an engine:

1. A blue signal must be attached to the controlling engine and be visible to the engineer or personnel controlling the engine.
2. The engine must not be moved. (See figure 3 below)

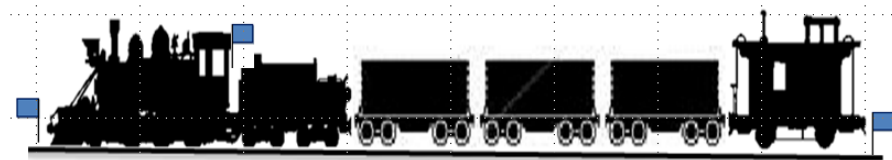

(Figure 3)

D. Protection for Emergency Repair Work

If a blue signal is not available for personnel performing emergency repairs on, under, or between an engine or rolling equipment coupled to an engine on the main loop track, the personnel controlling the engine must be notified and appropriate measures taken to provide protection for the personnel.

E. Movement in Engine and Car Repair and/or Service Area (Roundhouse)

An engine must not enter a repair and/or servicing track until the blue signal protection is removed from the entrance. The engine must stop short of coupling to another engine.

An engine must not leave a repair and/or servicing track unless the blue signal is removed from the engine and the track in the direction of movement.

Blue signal protection removed to let engines enter or leave the engine servicing area must be restored immediately after the engine enters or clears the area.

An engine protected by blue signals may be moved on a repair and/or servicing track when:

1. Any authorized personnel operate the engine under the direction of the personnel in charge of workmen.
2. The blue signal has been removed from the controlling engine to be repositioned.
3. Workmen have been warned of the movement.

The turntable may be aligned away from any track for blue signal protection on that track or all repair and/or servicing tracks. Turntable must be locked with an effective locking device and a blue signal displayed at the turntable locking stand that has the effective locking device. (see figure 4)

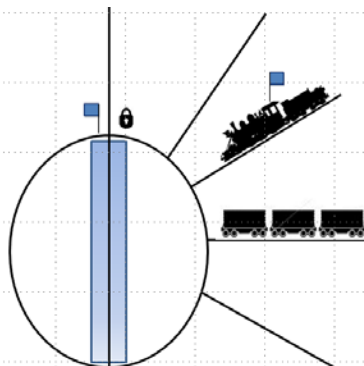

(Figure 4)

S9.0 Chemical Safety

- A. Wear safety glasses when applying finishing materials.
- B. Thinners and reducers such as naphtha, benzene, lacquer thinner, and enamel reducer should be applied in a well-ventilated room. Fumes have a toxic effect.
- C. Store all chemicals and soiled rags in proper safe containers. Many chemicals and rags are highly flammable
- D. Wear any approved respirator for finishing operations that involve the use of toxic chemicals such as lacquer thinner and enamel reducer.
- E. Spraying should be performed in a well-ventilated booth or outside to reduce toxic fumes.
- F. Wash your hands well after applying a finish in order to remove any toxic materials that you have handled.
- G. Provide an approved fire extinguisher in the finishing area.
- H. Use rubber gloves, goggles and other necessary protection when handling or working with battery acid, creosote, caustic soda, lye, oxalic acid or other chemicals injurious to the skin.
- I. Environmental Safety, always take measures to prevent:
 - Spills of oil or other material.
 - Discharge of contaminants to sewers, waterways, or the ground.
 - Smoke and gas emissions when operating combustion equipment.
- J. Safety Data Sheets are available for review at the appropriate museum facility. Treat all unidentified material as hazardous until identified. Do not transport unidentified material.
- K. Skin Cleaning; do not clean any part of your body with gasoline, solvents, or oily rags. Use company-supplied hand creams and soaps for cleaning hands, arms, face, and other parts of the body. If the skin has been exposed to corrosive agents (acids or bases), use plain water to flush continuously for at least fifteen minutes. Do not apply ointments, soaps, or creams to chemical or thermal burns.
- L. Protection from Silica-Containing Dust, whenever you are exposed to visible airborne dust arising from ballast, taconite, or sand, wear approved respiratory protection.
- M. Chemical Approval; do not bring a chemical product onto museum property until the chemical is approved.

S10.0 Electrical Safety

- A. Only authorized and trained personnel are permitted to work on electrical apparatus or equipment. Wear a dielectric hard hat when working where you could contact power lines or high-voltage equipment.
- B. Working on or touching electrical conductor or apparatus. unless authorized to do so, is prohibited. No work should be performed on any electrical equipment by anyone wearing a ring, wristwatch, or metallic hardhat.
- C. Operating switches bearing warning tag is prohibited.

- D. Removing warning tags from switches, without authority of person in charge of men for whose protection they were placed is prohibited.
- E. Use of water to extinguish fire near energized electrical equipment or apparatus is prohibited. Apply sand or other extinguishing means only after circuit has been de-energized. Have power removed when necessary to direct hose stream close to high-tension wire or apparatus.
- F. Use of extinguisher for fire around electrical circuit unless approved for the purpose is prohibited. Follow instructions applying to the particular make of extinguisher. When using chemical extinguisher, use care to avoid being overcome by the fumes. Keep as far as possible, during a fire, from energized high voltage conductor which might fall. Arrange to have such wire de-energized and grounded.
- G. Tampering with electrical fuses, or otherwise destroying their protective feature, except emergency work by qualified electricians, is prohibited. Fuses of larger than prescribed capacity are prohibited. Electric wires or apparatus must not be repaired except by authorized persons.
- H. Worn, frayed, or damaged electrical cords must not be used and turned into museum personnel for replacement. Assure that all electric operated devices are in good order before use.

S11.0 Cutting and Welding Equipment Safety

S11.1 General

- A. Personnel must be knowledgeable in safe practices before performing welding or cutting operations. Adequate ventilation must be in use when arc welding or cutting.
- B. A dry chemical fire extinguisher must be within 30 feet of any welding, cutting or open flame work.
- C. Inspect all leads, grounds, clamps, welding machines, hoses, gauges, torches and cylinders before each use. Remove defective equipment from service and inform appropriate museum personnel.
- D. Avoid breathing fumes. Use exhaust fans, blowers or a respirator.
- E. Each welder is responsible for containing sparks and slag and/or removing combustibles to prevent fires.
- F. Use appropriate mats and shields. Keep welding leads and burning hoses clear of passageways. Use protective welding screens when working near machinery.
- G. Performing cutting, welding or heating operation on container unless properly cleaned and vented to permit escape of gas or hot air is prohibited.
- H. Wear clothing and shoes that will give full body protection when performing gas or electric cutting or welding operation. Wearing torn or very oily or greasy clothing or gloves when performing gas or electric cutting or welding operation is prohibited.

- I. Make sure that the machine is turned off and valves closed when you have finished and that your work area has been cleaned up.
- J. When welding hoses or leads must cross the track, they must be placed under the rail.

S11.2 Electric Welding

- A. Approved goggles shall be worn with at least a #9 filter with a safety lens on both sides of the filter.
- B. An approved welding helmet shall be worn.
- C. All work must have a separate and adequate ground connection.
- D. All arcs should be shielded in operating areas.
- E. Never do electric welding from a metal ladder.

S11.3 Cutting (Gas Burning)

- A. Removing valve keys from acetylene cylinders while in use is prohibited.
- B. Wear appropriate PPE required for the job.
- C. Approved goggles shall be worn with at least a #3 filter with a safety lens on both sides of the filter.
- D. All hoses, gauges and torches shall be inspected before each use.
- E. Before connecting regulators to cylinders, carefully open the cylinder valve a crack to blow out any foreign particles. Close the valve. After the regulator is connected, stand to one side of the gauge while the cylinder valve is opened. Open the cylinder valve slowly.
- F. Be certain that the second stage of the regulator is closed BEFORE opening the cylinder valve.
- G. Open valves on fuel gas cylinders (propane, acetylene, natural gas) 1/4 turn only. Open oxygen cylinder valves wide open. Valve wrench must be kept in place during use.
- H. Do not exceed 15 PSI on the torch side of the gauge when using acetylene.
- I. When lighting a torch, open the fuel valve on the torch BEFORE opening the oxygen valve. Use an approved spark lighter. Do not use matches or cigarettes to light a torch. Hold torch in downward position and in direction away from others.
- J. Compressed gas cylinders must be tied off vertically to an adequate support while in storage, transit or use.
- K. Spare oxygen cylinders are to be stored separate from other compressed gases and flammables and must be tied off vertically to an adequate support.
- L. Do not use compressed gas to clean your clothing or to clean your work area.
- M. Place cylinders and hoses where they are not exposed to sparks and slag from the cutting operation.

- N. Keep oxygen away from oil or grease. Oil or grease, even in small quantities as found on gloves or overalls, will ignite violently when contacted by oxygen under pressure. Store torch where it will not be damaged
- O. Valve protection caps, where cylinder is designed to accept a cap, shall always be in place, hand tight, except when cylinders are in use or connected for use.
- P. Extreme care must be used when cutting rail or any other material that is under stress.

S12.0 Fire Prevention, Response and Hazards

- A. General Requirements, Know and understand area emergency plans and special instructions related to fire protection. In case of smoke or fire, notify all individuals who may be affected, supervisors, and appropriate emergency responders. Keep exit aisles, emergency exits, and fire doors clear. Keep areas around buildings, structures, and equipment free of fire hazards.
- B. Emergency Procedures Fight a fire only if properly trained and equipped and if your personal judgment dictates you can do so safely.
- C. Fire extinguishers and protection devices
 - Report any out-of-date, discharged, or defective fire extinguishers to proper authority.
 - Maintain clear access to fire extinguishers, alarm boxes, and other fire protection devices. Do not park vehicles or place material within 25 feet of fire hydrants.
 - Have an approved fire extinguisher readily available where the use of gasoline or an oil-burning device is authorized.
 - Never leave open flames unattended.
- D. Using gasoline, alcohol, or kerosene to start or intensify a fire in a stove is prohibited.
- E. Gasoline, kerosene or other flammable liquid must be stored in approved safety container until ready for use.
- F. Filling gasoline tanks inside tool house or in other enclosed space or while internal combustion engine is running is prohibited. Before drawing gasoline from supply located indoors, secure and keep in open position all windows and doors until building is entirely free of fumes.
- G. Lacquer, paint containing naphtha, mastic cement and other flammable, must not be stored near steam pipes or other heating facilities and must be kept away from open flames.
 - close cans of finishing materials and thinners immediately after use.
 - Use flammable liquids in very small quantities.
 - Be sure the container is labeled.
 - Dispose of oily rags and other combustible materials immediately, or store them in an approved container.

- Clean paint brushes when completely finished. **DO NOT LEAVE THEM STANDING IN THINNER!**

H. Do not allow stoves to become overheated.

I. Wearing of nylon or flammable type clothing near an open flame or sparks is prohibited.

#